

Overlay Wood Flooring System

Installation Guides

1. About Engineered Wood Flooring-----	03
2. Scope & Limitations-----	03
3. Environment & Condition-----	05
4. Safety & Health-----	07
5. Substrate Preparations-----	09
5.1 Cleaning & Drying-----	09
5.2 Sound & Smooth-----	09
5.3 Flat planeness-----	09
5.4 Leveling-----	10
5.5 Underfloor Heating-----	11
5.5.1 Hydronic-----	12
5.5.2 Electric-----	12
5.6 Acoustic Underlay-----	13
5.6.1 Before install-----	13
5.6.2 During install-----	13
5.7 Wet Areas Membrane System-----	15
5.7.1 Before install-----	16
5.7.2 During install-----	16
5.7.3 Wet Areas Detailed Guidelines-----	17
5.7.4 Membrane system Figures-----	19
6. Installation-----	23
6.1 Responsibility-----	23
6.2 Notice-----	23
6.3 Install Methods -----	23
6.3.1 Floating-----	24
6.3.2 Glue down-----	27
6.3.3 D3 PVA Adhesive at the joints-----	30
6.3.4 Sealed Wet Areas-----	31
7. Post-Installation Work-----	33

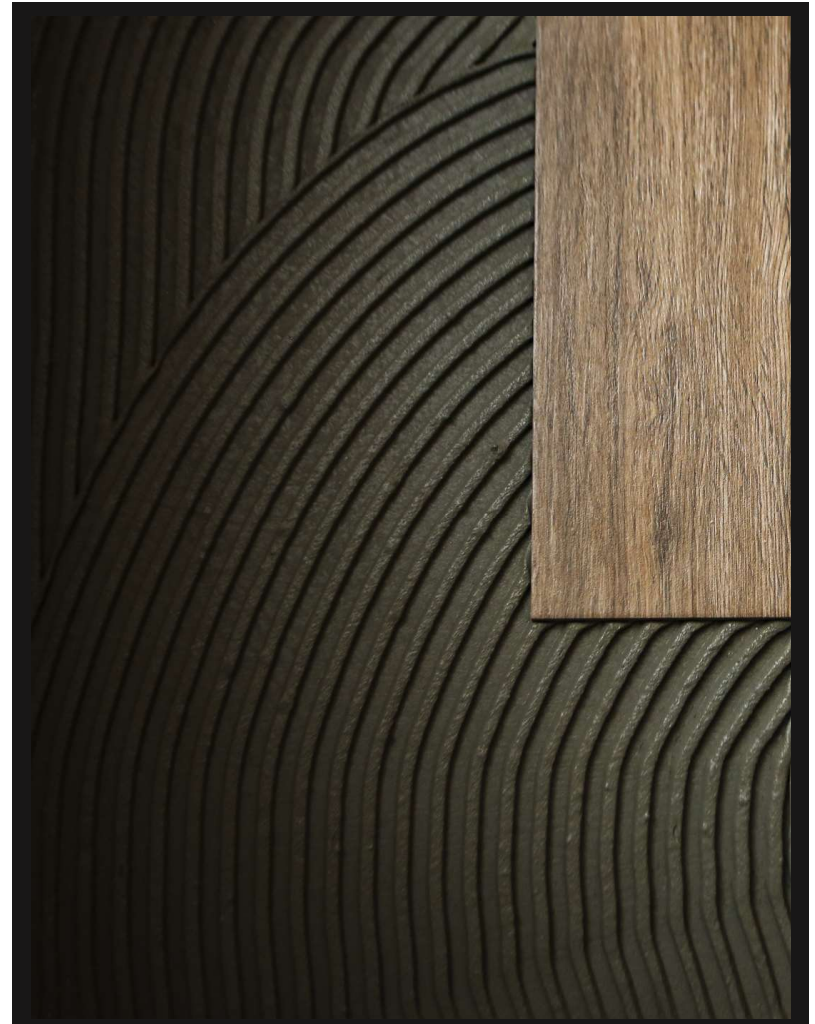

1. About Engineered Wood Flooring

Assuring good stability, engineered flooring remains all the appearance and features of solid timber flooring with a decorative layer of solid timber at first and another timber or other materials beneath, which can differ clearly in their construction, maybe stacked as floating floors, and is glued to a subfloor as an overlay or in some circumstances is fixed as a structural floor.

Constructions Obviously, products that own various board constructions, and different product designs in the present market will be taken into consideration. There are two general product types that have been rolled out for certain years; the first type owns a face lamella, core block layer, and stabilization layer, and the other type restricts a face lamella over a plywood base (typically referred to as 3 layers)

Wood flooring requires installation using either FLOATING or GLUE-DOWN methods. However, regardless of the installation method, adherence to installation conditions is necessary.

2. Scope & Limitations on the use

-----Overlay Engineered Wood Flooring System

This overlay Engineered Wood Flooring system is for commercial and residential indoor use and is not to be used outdoors. Violation of this will result in the warranty being voided.

This product is suitable for all areas except commercial kitchen and garages.
The Subfloor must be level in accordance with NZS/AS 1884:2013 (3mm variation over a 3m long straight edge)
The product must be installed onto an approved subfloor.
When used in wet areas, the provisions of this installation guide must be followed to ensure the flooring performs properly post-installation.
The products are used with underfloor heating systems, the provisions of this installation guide must be followed to ensure the flooring performs properly post-installation.
During maintenance and clean, the maintenance and care guide provided by Myfloors.co.nz must be adhered to.
For installations where both the length and width of the Product will be less than 12 x 8meters. If exceeding this measurement, please choose to use a divider transition trim.
The product needs to comply with the NZBC C AS/1, maintaining a distance from combustion appliances.



3. Environment & Conditions

-----Recommendations

lease store the packets 48 hours prior to installation under the same climatic conditions (temperature and moisture) as the actual installation process.

Important pre-condition for proper fitting and long-term use of the laminated flooring is a room temperature of 18 – 24°C and a relative humidity of around 40 – 70%.

it is essential to keep the flooring dry and free from moisture. Moreover, the flooring should never be placed outdoors.

Maintaining a stable indoor temperature and humidity over a certain period of time is crucial. Greater shrinkage would be caused by the lower humidity, and greater expansion would be caused by the higher humidity. Certain issues (such as squeaking in an existing plank or sheet subfloor or the integrity of tile fixation)

Necessary Materials and Tools: Adhesive, moisture barrier, polyethylene foil or moisture barrier underlayment, aluminum jointing tape, separation shims, fit-up aid, and footfall sound insulation.

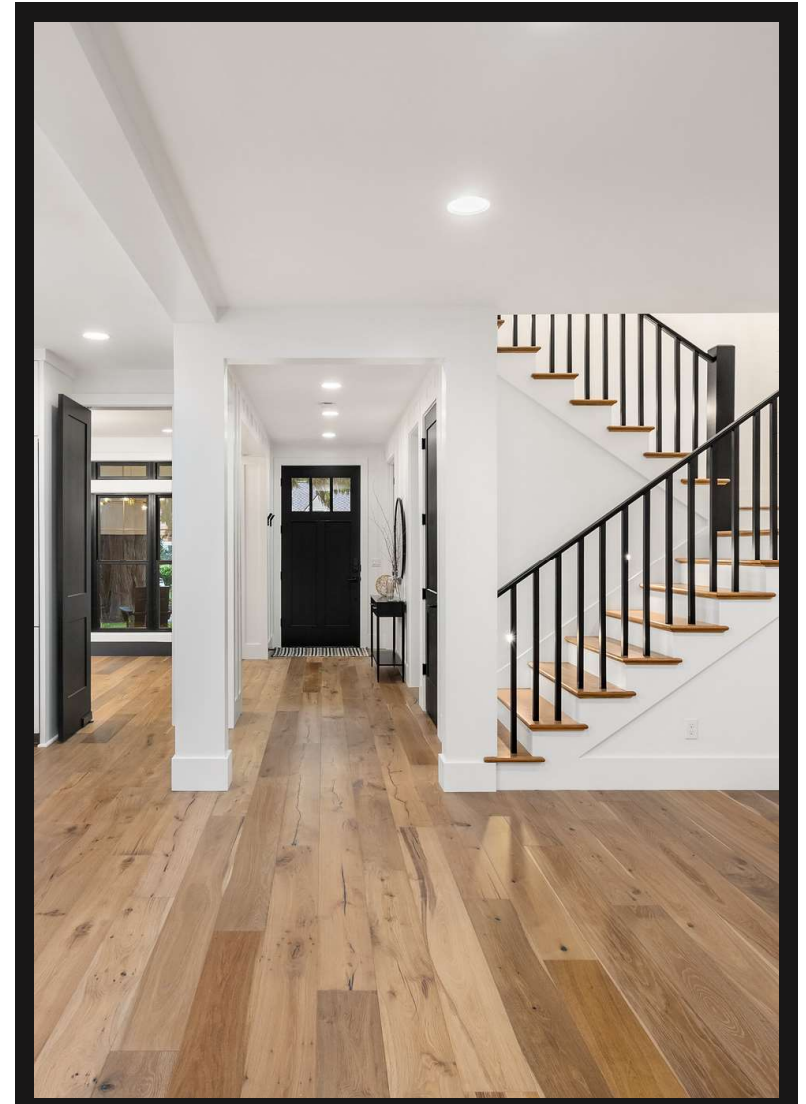

4. Safety & Health

-----**In every scenario, safety and Health takes precedence**

Be it tools, the site, or materials, should they pose a threat to your safety and health, it's imperative to exit the area immediately.

To further ensure your safety and well-being, please following protective gear:

- ✧ Safety Glasses: To shield your eyes from flying debris.
- ✧ Ear Protection: To safeguard your hearing amidst noisy environments.
- ✧ Masks: To prevent inhalation of harmful dust and particles.
- ✧ Safety Vest: To enhance your visibility on site.
- ✧ Steel Toe Shoes: To protect your feet from heavy falling objects.

Equipment safety is paramount. For instance, while using a saw for cutting tasks, never remove the saw's protective covering. This precaution is crucial to prevent accidental injuries.

Note:

Engaging in woodworking may expose individuals to fine wood dust, which has been associated with nasal cancer in some instances. Additionally, specific types of wood such as Spotted Gum might be treated; therefore, it's not recommended to dispose of the resulting sawdust, shavings, or offcuts by burning. It's prudent to consult local Council By-Laws to ascertain the correct disposal procedures for treated wood.

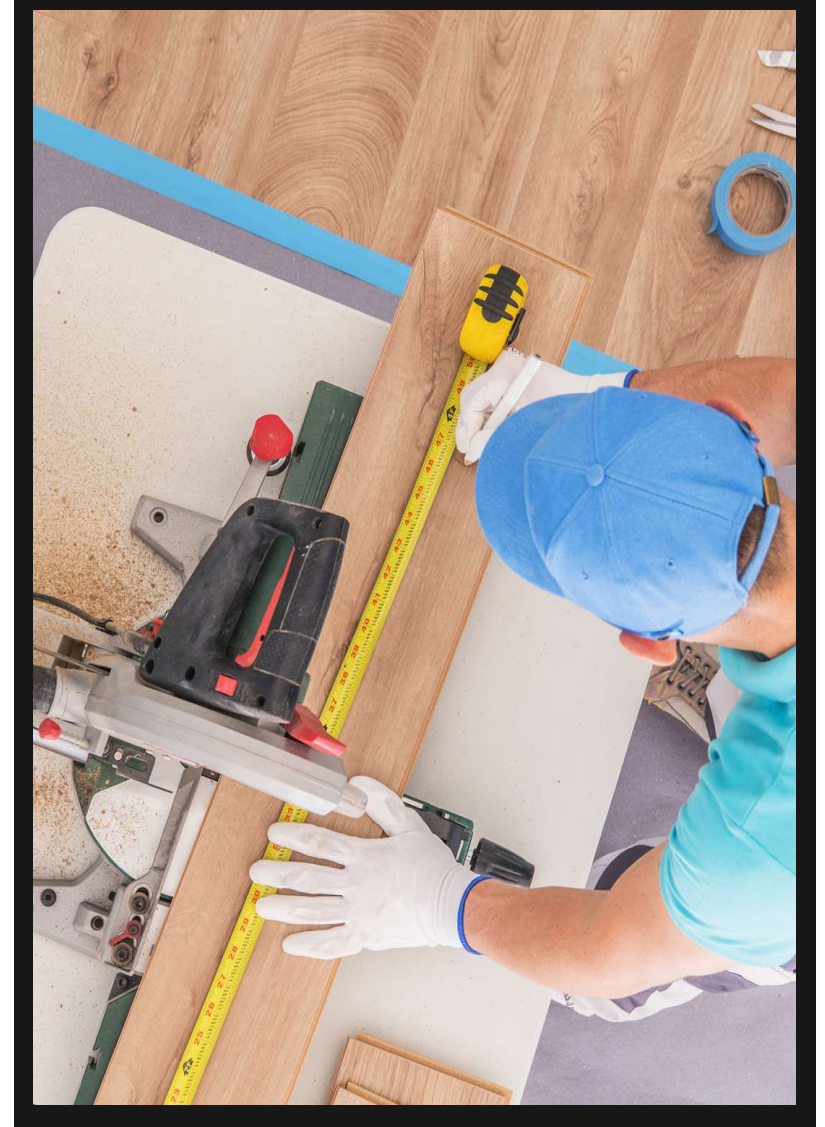

5. Concrete & Timber Substrate Preparations

5.1 Clean & Dry

Remove or clean all surface contaminants- any glue or sticky adhesive residue needs to be mechanically eradicated to avoid any clicking sounds that might be heard when walking across the finished floor.

Concrete and timber while the surface of these substrates may appear dry, it is after the installation of the flooring product that any potential moisture can be drawn to the surface causing bubbling and swelling of the product. This can be caused by the concrete slab blocking off the crossflow ventilation. The result creates moisture build-up beneath the building.

Both substrates should be moisture tested at the early planning stages of an installation a moisture content reading that is more than 16% may indicate a moisture problem beneath the floor. Providing adequate subfloor ventilation and vapor membrane is crucial.

5.2 Sound & Smooth

Alongside any loose, rotten, or springy boards, inspect for flexing and stability at the joint where timber meets concrete. This joint represents the weakest point susceptible to movement under load, heat, moisture, or seismic activity.

The surface should exhibit smoothness with no detectable ridges when a hand is glided over it.

5.3 Flat Planeness

When a 3000mm long straightedge is laid at rest on two points spaced 3000mm apart on the surface, no portion of the surface should be more than 3mm beneath the straightedge. NZS AS1884:2013

5.4 Leveling

In situations where there is a substantial discrepancy in the level of the floor, utilizing Plywood can effectively resolve the unevenness. When the discrepancy is minor, using a screed or leveling compound can smooth out the irregularities, providing a flat and stable surface for further flooring installations.

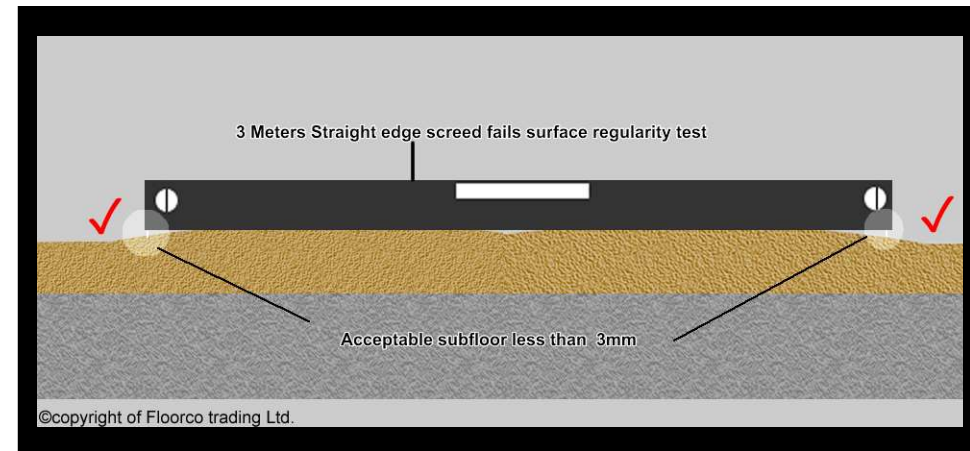
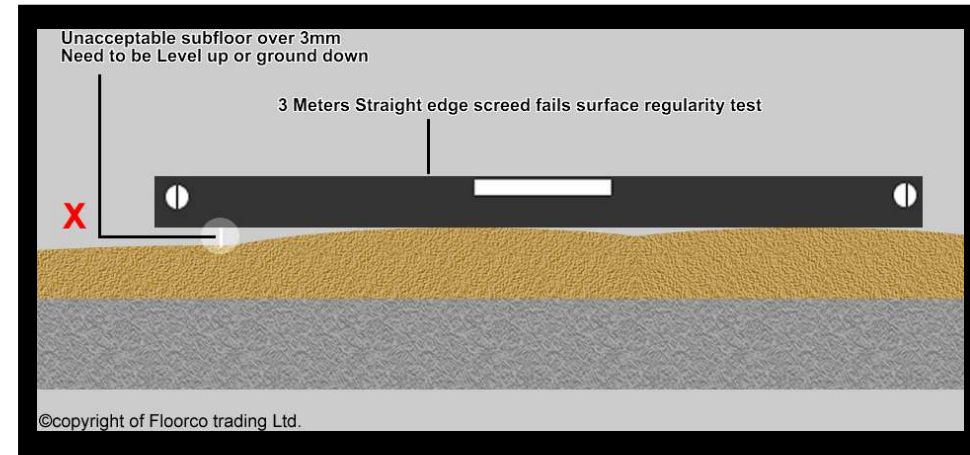

5.5 Underfloor Heating

Before the installation, please ensure that the timber flooring chosen for installation is compatible. Install underfloor heating, preparation as per this guide is necessary. Additionally, we recommend the flooring installer to liaise with the underfloor heating contractor to ensure correct installation.

- ✓ If there's a conflict between the guidelines of the underfloor heating manufacturer and this guide, always follow the guidelines of the underfloor heating manufacturer.
- ✓ The temperature of the underfloor heating system should not exceed 27°C.
- ✓ turned on prior to installation of the floor covering for a minimum of seven days to assist with the acclimatization of the substrate.
- ✓ When the underfloor heating system is restarted after being turned off, the temperature should be gradually increased to reach 27°C over a period of 4-5 days.
- ✓ Do not frequently adjust the temperature of the underfloor heating system, it is permissible. to decrease or increase the temperature by a maximum of 2°C per day. NZS AS1884:2013
- ✓ The temperature should be maintained at 15°C during the flooring installation, and this temperature should be sustained for at least 48 hours post-installation.
- ✓ the presence of underfloor heating and security systems shall be checked and all preliminary work, such as the fixing of floor sockets for service plugs, shall be completed.
- ✓ Perform a concluding inspection to ascertain that the substrate is thoroughly dry, clean, level, devoid of any cracks, and structurally robust prior to advancing with the installation.

5.5.1 Hydronic

- ✓ The elevation of the slab surface from the heating tubes should not be less than 30mm, with a recommended thickness of 60mm.
- ✓ The distance (width) between heating tubes should not exceed 150mm.
- ✓ Before installing the flooring, please ensure that the humidity of the ground is no higher than 15%, and moisture should comply with the requirements of section 5.1 in this guide.

5.5.2 Electric

- ✓ Installers need to ensure that this product is suitable for use with underfloor heating systems.
- ✓ ensure that the screed is at least 8mm above the wires.
- ✓ Before initiating the installation, it is imperative to test the substrate, which should exhibit a reading of 70% Relative Humidity (RH) or below.
- ✓ The installation must ensure that the subfloor is structurally sound and meets the good requirements of section 5.2 in this guide.

Note:

Should any of the aforementioned points be unachievable, please cease installation immediately. Forcing installation implies subsequent unknown risks; please contact us.

5.6 Acoustic Underlay

5.6.1

Before Installation

- ✓ Prior to the installation of the acoustic underlay, please prepare according to the " Substrate Preparations " section of this guide.
- ✓ The flooring installer can carry out the installation of this acoustic underlay and can inspect that the subfloor has been adequately prepared.

5.6.2

During Installation

- ✓ Adhere to the moisture test requirements, no higher than 70% Relative Humidity, and humidity within 15%.
- ✓ Also, follow the requirements for leveling evenness.
- ✓ Fully glue use a notched trowel to spread the glue evenly over the subfloor.

Note:

If the above instructions cannot be adhered to due to special circumstances, please refrain from installing the acoustic underlay or flooring. Should any of the aforementioned points be unachievable, please cease installation immediately. Forcing installation implies subsequent unknown risks; please contact us.



Fully Glue-down Wood flooring



Fully Glue-down Wood flooring



Floating Wood flooring

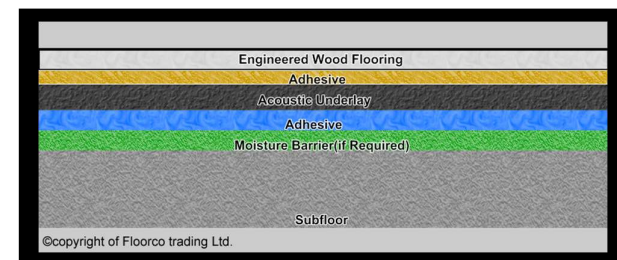

Floating Wood flooring

5.7 Wet Areas Membrane System E3/AS2

Note: wet areas membrane system is used for wet areas such as kitchens, bathrooms, toilets, and laundries.

The "wet areas waterproof membrane" is a pathway to comply with the E3 building code and is suitable for most Substrates.

Refer to the **Code of Practice for Internal Wet-area Membrane Systems** for more information.

Submit in compliance with E3/AS2 by designating a Wet Area Membrane following the "Code of Practice for Internal Wet-area Membrane Systems" the membrane should be laid under when the flooring will be placed.

For the environments where Wet-area Membrane Systems are used, please refer to the table below:

Substrate	Wet area membrane systems
Concrete – slab-on-Grade or suspended	Yes
H3 Treated plywood	Yes
H1.2 Solid Pinus / H1.2 Douglas Fir	Yes
Existing Solid Native Timber	Yes
Particle board / Oriented Strand board	No
Untreated Plywood or other subfloors	No

Note: By E3/AS2 solution states, "Particleboard must not be used as a new substrate in any wet area", and so should not be specified for use in any new construction in wet areas.

Note:
By E3/AS2 solution states, "Particleboard must not be used as a new substrate in any wet area", and so should not be specified for use in any new construction in wet areas.

5.7.1 Before Installation

Before installing the Wet-area membrane system, the subfloor should be prepared in accordance with these guidelines.

- ✓ Ensure that the wet-area membrane is compatible with the flooring.
- ✓ Ensure that the wet-area membrane is compatible with sealers, leveling agents, adhesives, and moisture-proofing.
- ✓ Install in accordance with E3/AS2 requirements.

5.7.2 During Installation

- ✓ When installing on wet-area membrane systems, please adhere to the following guidelines:
- ✓ Humidity Test: Ensure a reading of RH 70% or lower.
- ✓ Ensure the subfloor is level, dry, clean, and structurally sound.

5.7.3 Wet Areas Detailed Guidelines

When installing, please ensure strict adherence to the '[Code of Practice for Wet Area Membrane Systems](#).' This will ensure the installation's compliance.

1) Water-stop at the termination of the waterproof membrane system

- ✓ Figure 14: Water-stop at termination of waterproof membrane system
- ✓ Figure 18: Plan view of water-stop under a door jamb
- ✓ Figure 19: Elevation/edge of door jamb with water-stop under door
- ✓ Figure 20: Face of door jamb with water-stop under door

2) Cabinetry Water-stops

- ✓ Figure 15: Waterproof membrane system installed before cabinetry
- ✓ Figure 16: Tiles and waterproof membrane system under cabinet
- ✓ Figure 17: Waterproof membrane system installed after cabinetry

3) Floor-to-wall Junction.

- ✓ Figure 21: Waterproof membrane system behind skirting – up to 75mm

4) Penetrations for Piped Services

- ✓ Figure 27: Waterproof membrane system into floor waste outlet
- ✓ Figure 28: Pipe penetrations

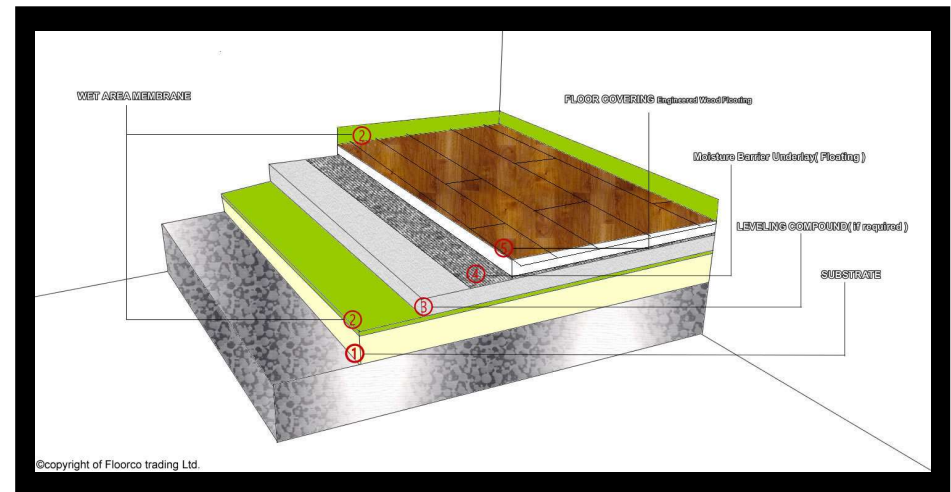
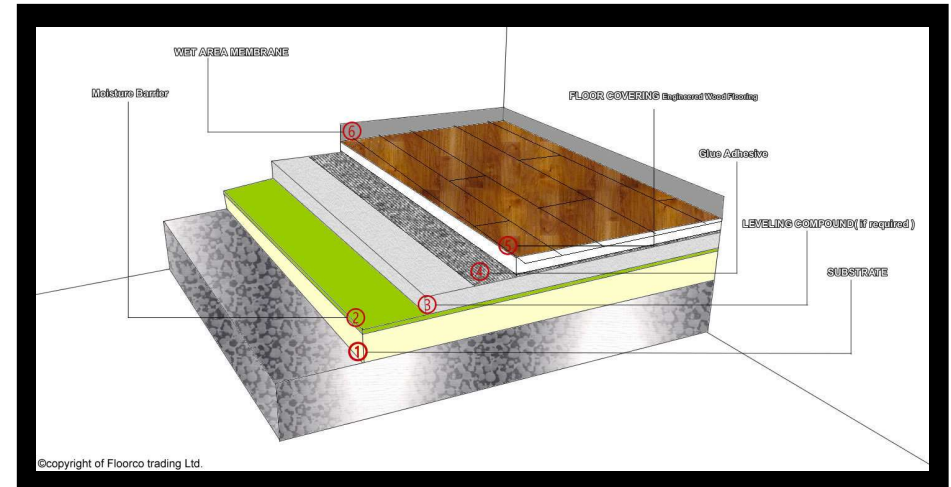

5.7.4 Wet Areas Membrane System Figures

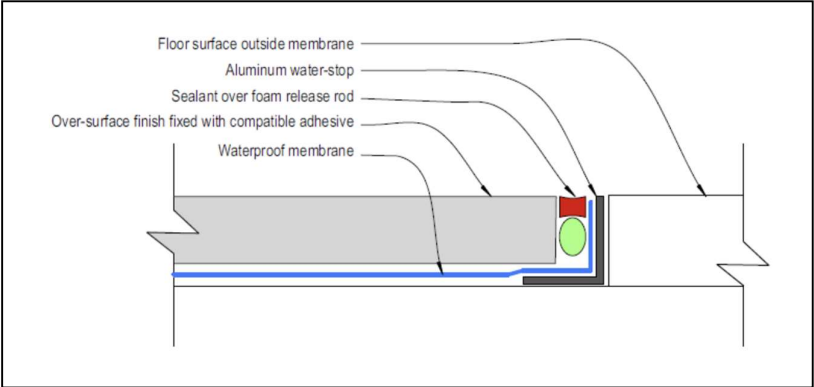

Figure 14: Water-stop at termination of waterproof membrane system

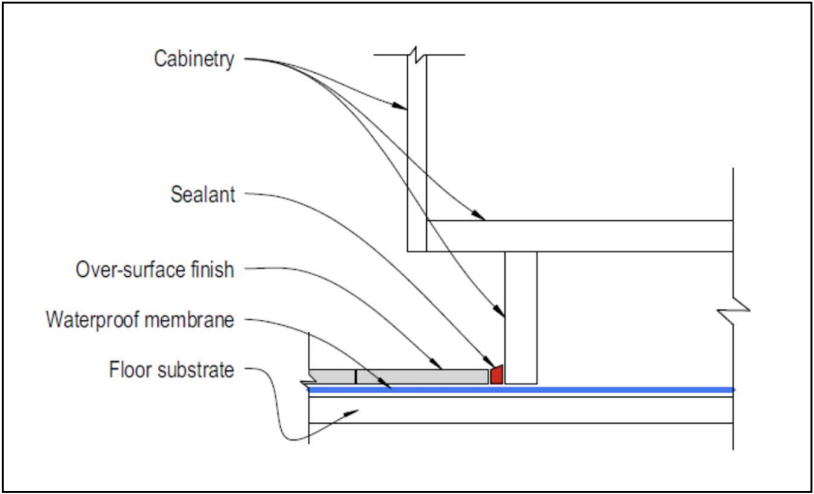

Figure 15: Waterproof membrane system installed before cabinetry

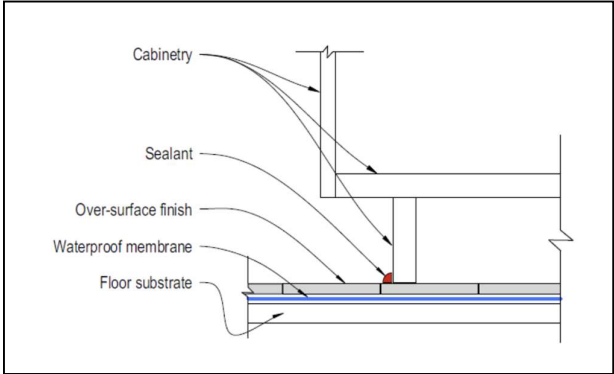

Figure 16: Tiles and waterproof membrane system under cabinet

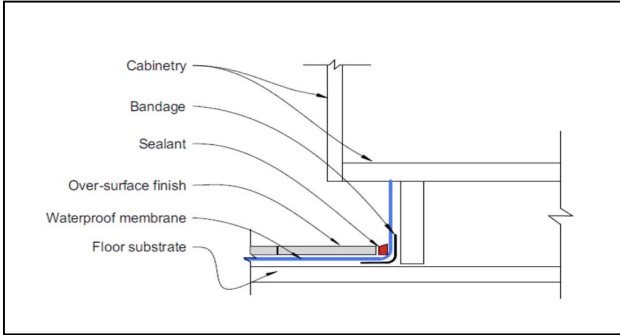

Figure 17: Waterproof membrane system installed after cabinetry

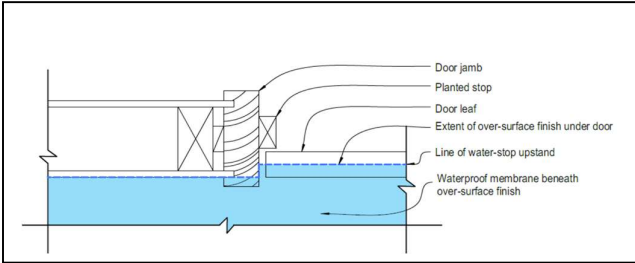

Figure 18: Plan view of water-stop under a door jam

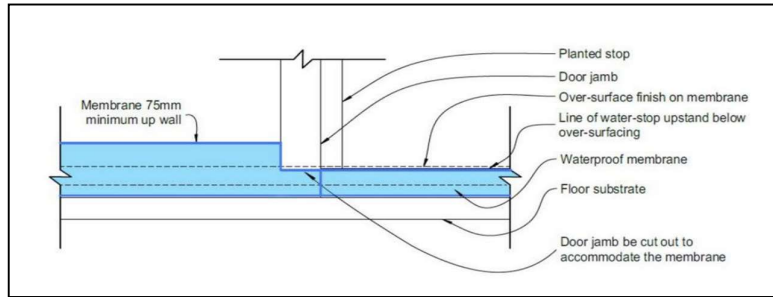

Figure 19: Elevation/edge of door jamb with water-stop under door

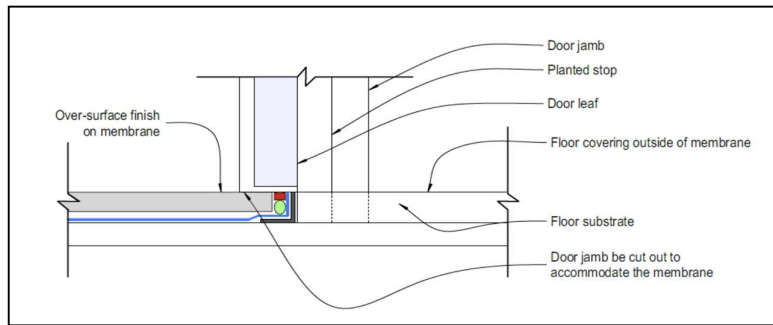

Figure 20: Face of door jamb with water-stop under door

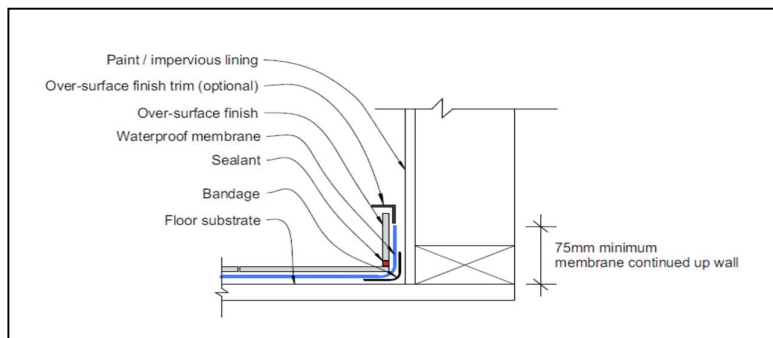

Figure 21: Waterproof membrane system behind skirting

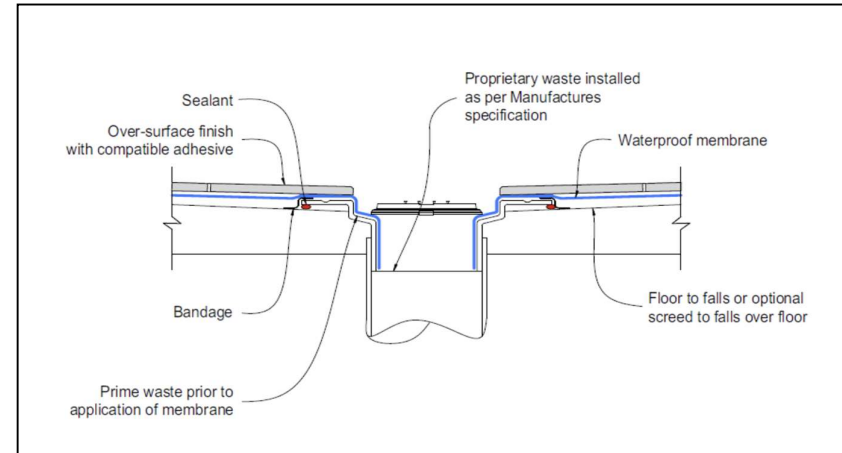

Figure 27: Waterproof membrane system into floor waste outlet

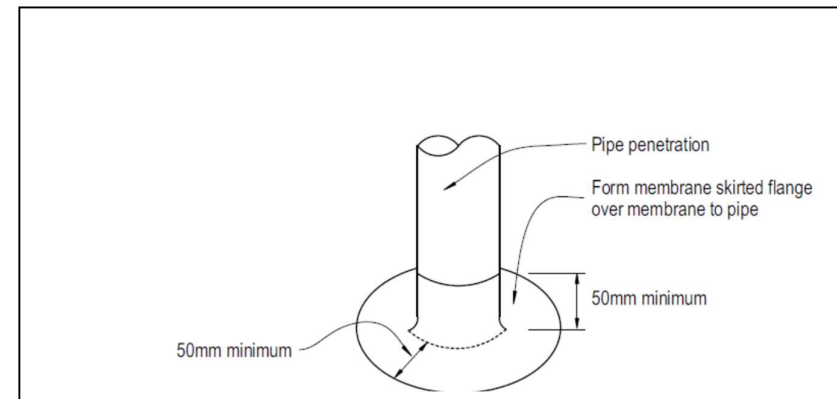

Figure 28: Pipe penetrations

6. Installation

6.1 Responsibility

The flooring installer should conduct a thorough inspection for defects and damage on the flooring. If a particular board or several boards are found to be unsatisfactory, please do not install them. Upon completion of the installation, it implies that the installer has accepted the materials, and the flooring will not be subject to claim protection.

Some aesthetically displeasing boards are not unusable. They can still be placed in less conspicuous areas like storage rooms, closets, or corners of rooms. The Engineered wood flooring products are natural wood grain, appearance is not considered a defect

And the installer has the responsibility to follow this guide for installation, violating this guide will render the flooring ineligible for claim protection. If there are any questions, feel free to contact us.

The builder, owner, or end-user must provide temperature control devices. If it's colder than specified, don't install flooring until devices run for 48 hours to condition the material. these devices shall remain on during the installation and for a minimum of 48 hours thereafter. NZS AS1884:2013

6.2 Notice

The maximum dimensions for the flooring are 8m x 8m, and a minimum expansion gap of 10 mm should be left every 8 meters.

Please ensure that the base material is level, solid, clean, and dry, as detailed in "Substrate Preparations" of this guide. Failure to adhere to this guide will result in warranty voidance.

Avoid direct sunlight 24 hours before, during, and 24 hours after installation to prevent heat-caused size changes.

6.3 Install Methods

Engineered Wood Flooring has two installation methods, one method is GLUE DOWN, and the other is FLOATING.

6.3.1 Floating Methods

Floating Method installation refers to a method of installing Engineered wood flooring without the need for nails, or staples. The engineered wood flooring is designed to lock together or glue along the edges, creating a floating floor over the subfloor.

Preparation

- ✓ Remove existing molding and clean sub-floors. Level uneven sub-floors if necessary. Please ensure to follow the content of "Concrete & Timber Substrate Preparations." in this guide.
- ✓ Roll out 2mm - 5mm moisture barrier underlay to cover the subfloor, especially if the installation is above or at ground level. Run the underlayment 20mm to 30mm up the walls and secure it in place with tape. 100% fully coverage sub-floor and sealed.
- ✓ Identify the longest, straightest wall to begin the installation.
- ✓ Measure and mark the flooring width plus 10mm for expansion from the starting wall, snapping a chalk line for guidance.
- ✓ Take into account extra expansion gaps for strong sunlight exposure, and when installing. on plywood or particle board sub-floors. Please ensure to follow the content of " Substrate Preparations" in this guide.

Preparing the starter row

- ✓ Select the longest and straightest boards for the first rows.
- ✓ Align and install the boards, ensuring a 10mm expansion gap from the end wall, and stagger the joints with a minimum end stagger of 152mm.
- ✓ Measure the total width of the flooring (including the tongue), plus 10mm for expansion. Measure out this distance in at least 2 places from the starting wall and 30cm from the corners. Then, snap a chalk line parallel to the starting wall.

Subsequent Rows

- ✓ Continue laying out the planks, working from at least four open cartons to blend the planks and stagger the end joints for a pleasing appearance.

Click-Lock Install [1]

- ✓ Attach the next board to the shorter edge and lower down. Press the shorter edge of the board with a hand, and the lock will close. The board, cut as described above, is placed with the front lock towards the preceding board. Use the cut portion of the board to start the second strip of the floor. Insert it into the lock at an angle of 20°-30°.
- ✓ Then interlock the longitudinal side by pulling the elements together. As long as there is no visible gap between the elements, the connection has been sealed correctly and the element can be fully laid out flat on the floor. If a gap exists, repeat the previous process but with more pressure and check the row beforehand.
- ✓ It may be necessary to rip the last row to allow for the 10mm expansion. If the last row is 3cm or less click the pieces to the last full uninstalled row and install them together. If needed use a light rubber mallet to make the remaining rows tight to the installed planks.

Gluing T&G [2]

- ✓ In a floating floor installation, the flooring is not glued or nailed to the underlayment but is glued in the board's side and end grooves. This is achieved by applying a bead of glue on the upper side of the groove along the entire length and on the end of each plank with silicone-based T & G glue. If click-lock system please see [1]
- ✓ Turn the board upside down when applying the adhesive to achieve proper application, when the board is turned again for installation with the finish side up, this will allow the adhesive to flow down and give better coverage. Do not apply adhesive on the top of the tongue. If click-lock system please see [1]
- ✓ Do not apply adhesive on the top of the tongue. If click-lock system, please see [1]

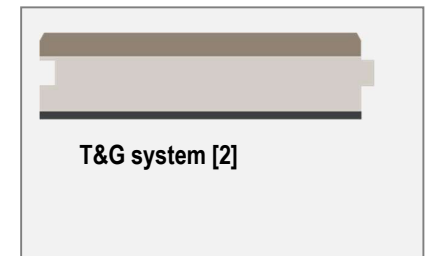
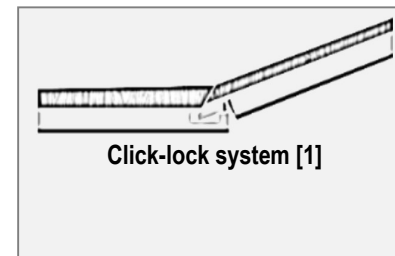

Note: It's crucial to note whether the product is T&G (Tongue and Groove) or CLICK-LOCK before installation.

6.3.2

Glue Down Methods

The **glue-down Method** involves fixing your floor directly to the substrate using an adhesive. This is Engineered wood flooring's preferred method of installation for most circumstances as it provides a floor that is firmer and quieter to walk on and eliminates the risk of squeaking joints.

Preparation

- ✓ Remove existing molding and clean sub-floors. Level uneven sub-floors if necessary. Please ensure to follow the content of "Concrete & Timber Substrate Preparations." in this guide.
- ✓ Roll out 0.6mm - 1.2mm PE membrane underlay to cover the subfloor, especially if the installation is above or at ground level. Run the underlayment 20mm to 30mm up the walls and secure it in place with tape. 100% fully coverage sub-floor and sealed.
- ✓ Identify the longest, straightest wall to begin the installation.
- ✓ Measure and mark the flooring width plus 10mm for expansion from the starting wall, snapping a chalk line for guidance.
- ✓ Take into account extra expansion gaps for strong sunlight exposure, and when installing, on plywood or particle board sub-floors. Please ensure to follow the content of " Substrate Preparations" in this guide.

Preparing the starter row

- ✓ Select the longest and straightest boards for the first rows.
- ✓ Align and install the boards, ensuring a 10mm expansion gap from the end wall, and stagger the joints with a minimum end stagger of 152mm.
- ✓ Measure the total width of the flooring (including the tongue), plus 10mm for expansion. Measure out this distance in at least 2 places from the starting wall and 30cm from the corners. Then, snap a chalk line parallel to the starting wall.

Subsequent Rows

- ✓ Continue laying out the planks, working from at least four open cartons to blend the planks and stagger the end joints for a pleasing appearance.

Fully Glue-Dwon Install

- ✓ Apply the recommended adhesive with a trowel according to the manufacturer installation instructions (found on the adhesive pail) for the specific adhesive that is being used. Vapor barrier and Adhesive require 100% fully glued to the Subfloor.
- ✓ Always select your strips The more deeply colored strips should be installed where they are less visible. Pieces with flaws should be recut.
- ✓ Using the working area to install your flooring, line up the first strip with the tongue facing the wall, then press the strip into the adhesive and against the holding block. When you get to the final row you will likely find it necessary to rip-saw the strips to fit against the wall. Install using the pry bar and leave 10mm minimum expansion spaces.

6.3.4

Sealed Kitchen,Laundries,toilet and bathroom

To further protect the perimeters and joints from water ingress, the Installer will seal gaps between planks in the Kitchen, toilet, laundry, and bathroom. In open-plan spaces, the flooring surface shall extend at least 1.5 m from all sanitary fixtures and sanitary appliances. The sealed and transparent silicone adhesive should be used at the ends of planks and the long edge of the plank, this must also include perimeter protection from water ingress.

A PVA/silicone adhesive sealer that is water-impervious (with a minimum rating of D3) is necessary for all joints (both along the length and at the ends of the planks) during the installation process.

In the first, a thick and even layer of the adhesive should be applied to the groove edge, followed by an application to the top of the tongue. The planks should then be brought together and secured tightly. Any excess adhesive should be promptly wiped off with a wet rag or wipe.

It's crucial to adhere to all the guidelines specified in the D3 PVA/Silicone supplier's Installation sheet and this Installation guideline.

This is to be done to achieve an impervious surface, which is required by Clause E3 of the New Zealand Building Code.

Recommended silicone brands, [Bona](#), [Selleys](#), [Staerk](#), etc.

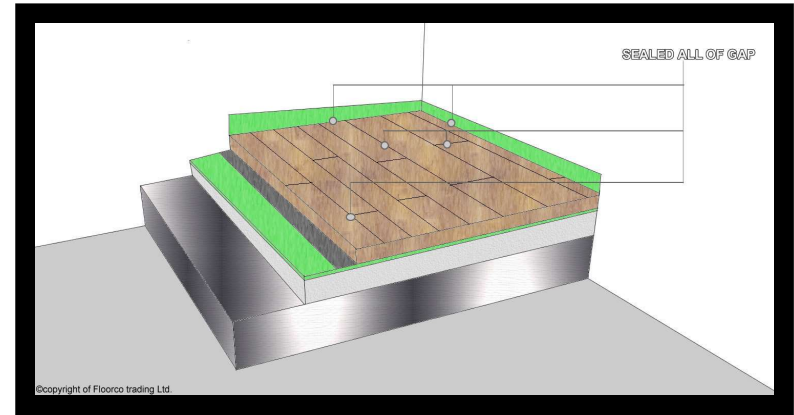

7. Post-Installation Work

- ✓ Clean the floor with any high-quality, wood lacquer cleaner.
- ✓ Install transition pieces -i.e. – thresholds, t-moldings, base shoe. Always secure moldings to the wall, not the floor.
- ✓ Any unused material should be stored in a dry place in case future repairs are needed. We recommend saving at least 2 boxes.
- ✓ To reduce the risk of fine dust particles, typically originating from plasterboard or drywall products, infiltrating the grain of the flooring, make certain that all cutting machinery is equipped with dust collection bags.
- ✓ In cases where fine dust has been produced in the vicinity during installation, it's essential to vacuum the floor post-installation and promptly shield it with a breathable floor protection product after the vacuuming process.
- ✓ To avoid shifting or gapping of the flooring during installation, lay perpendicular strips of 3M tape to hold the strips together.
- ✓ Remove the tape within 24 hours. Avoid the use of masking tape, which leaves an adhesive residue and may cause damage to the flooring.
- ✓ Please refrain from placing mats or rugs on the installed flooring for the first six months. This can cause color discrepancies between the area under the mats or rugs and the uncovered sections of the flooring.



References

1. Code of Practice for Wet Area Membrane Systems page45 – page52, 4th Edition published August, 2020 – By the Waterproofing Membrane Association Incorporated (previously the Membrane Group of New Zealand)
2. Floor coverings resilient sheet and tiles installation practices. By NZS/AS1884:2013 – New Zealand Standard.
3. Resilient floor coverings planning and installation 1st Edition 2019 – By The Flooring Association for the flooring industry.
4. Timber Flooring industry standard, By Australasian Timber Flooring Association

Contact
